



US007559102B1

(12) **United States Patent**  
**Benzo et al.**

(10) **Patent No.:** **US 7,559,102 B1**  
(45) **Date of Patent:** **Jul. 14, 2009**

(54) **ADJUSTABLE BED WITH SLIDING SUBFRAME FOR TORSO SECTION**

(75) Inventors: **Eduardo Rene Benzo**, Celina (AR); **Rodolfo W. Ferraresi**, Cumming, GA (US); **Mario Cesar Eleonori**, Martinez (AR)

(73) Assignee: **Bedlab, LLC**, Cumming, GA (US)

(\*) Notice: Subject to any disclaimer, the term of this patent is extended or adjusted under 35 U.S.C. 154(b) by 0 days.

(21) Appl. No.: **12/120,363**

(22) Filed: **May 14, 2008**

(51) **Int. Cl.**  
**A61G 7/015** (2006.01)

(52) **U.S. Cl.** ..... **5/618; 5/617**

(58) **Field of Classification Search** ..... **5/618, 5/617, 613, 616, 614**

See application file for complete search history.

(56) **References Cited**

U.S. PATENT DOCUMENTS

0,984,879 A	2/1911	Bartholome	
2,297,105 A	9/1942	Laukhuff	
2,400,155 A	5/1946	Letschert et al.	
2,587,068 A	2/1952	Sanders	
2,651,785 A	9/1953	Berner	
3,281,141 A	10/1966	Smiley et al.	
3,477,071 A	11/1969	Emerson	
3,593,350 A *	7/1971	Knight et al.	5/616
3,821,821 A *	7/1974	Burst et al.	5/616
3,875,598 A	4/1975	Foster et al.	
3,895,403 A	7/1975	Davis	
3,905,055 A	9/1975	Blair	
3,959,832 A	6/1976	Parsons	
4,006,499 A	2/1977	Young	
4,183,109 A	1/1980	Howell	
4,425,673 A	1/1984	Werner	
4,446,587 A	5/1984	Jump	
4,536,903 A	8/1985	Parker	

4,654,903 A	4/1987	Chubb et al.	
4,685,159 A *	8/1987	Oetiker	5/608
4,868,937 A	9/1989	Connoly	
4,947,496 A	8/1990	Connoly	
4,996,731 A	3/1991	Kruyt	
5,023,967 A	6/1991	Ferrand	
5,142,719 A	9/1992	Vrzalik	
5,161,274 A	11/1992	Hayes et al.	
5,438,723 A	8/1995	Carroll	
5,500,964 A	3/1996	Bergersen	
5,568,661 A	10/1996	Bathrick et al.	
5,577,280 A	11/1996	Elliott	
5,608,932 A	3/1997	Hasegawa	
5,611,096 A	3/1997	Bartlett	
5,640,730 A	6/1997	Godette	
5,781,949 A	7/1998	Weismiller	
5,790,997 A	8/1998	Ruehl	
5,802,640 A	9/1998	Ferrand et al.	
5,862,551 A	1/1999	Oguma et al.	
6,006,379 A *	12/1999	Hensley	5/618
6,088,853 A *	7/2000	Jansen	5/618
6,101,647 A *	8/2000	Stroud et al.	5/618
6,154,900 A	12/2000	Shaw	

(Continued)

*Primary Examiner*—Alexander Grosz  
(74) *Attorney, Agent, or Firm*—Eric W. Cernyar

(57) **ABSTRACT**

A sliding subframe mounted to the derriere-supporting section of an articulating bed is adapted to translate the rotational axis of the torso-supporting section of the bed toward the headframe as the torso-supporting section is raised to an inclined position, and back toward the footboard as the torso-supporting section is lowered to a level position. This mechanism reduces compression of the lumbo-sacral area of the patient during bed articulation.

**20 Claims, 16 Drawing Sheets**

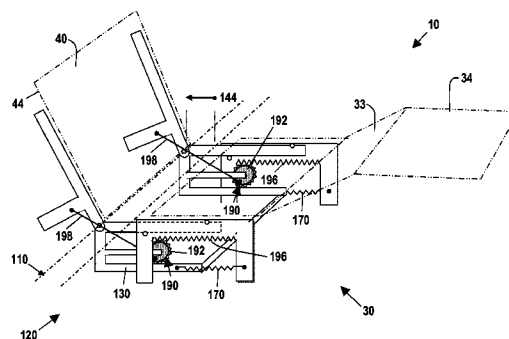
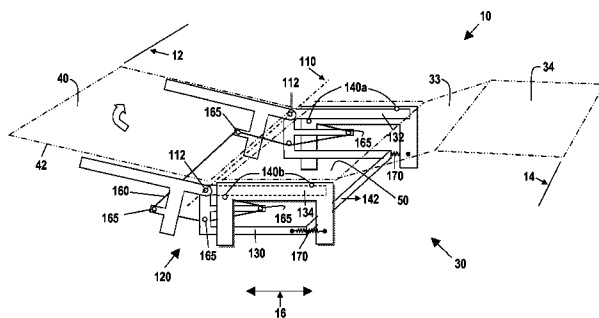

# US 7,559,102 B1

Page 2

---

U.S. PATENT DOCUMENTS							
				6,658,680	B2	12/2003	Osborne et al.
				6,892,405	B1	5/2005	Dimitrio
6,212,713	B1 *	4/2001	Kuck et al. ....	7,032,261	B2	4/2006	Heimbrock
			5/617				
6,216,295	B1	4/2001	Pearson	7,036,166	B2 *	5/2006	Kramer et al. ....
							5/618
6,289,536	B1	9/2001	Betson	7,441,291	B2 *	10/2008	Hayes et al. ....
							5/618
6,378,148	B1	4/2002	Votel	2004/0148704	A1 *	8/2004	Tekulve ....
							5/618
6,499,162	B1 *	12/2002	Lu .....				
			5/618				
6,640,365	B1 *	11/2003	Chang .....				
			5/618				

\* cited by examiner

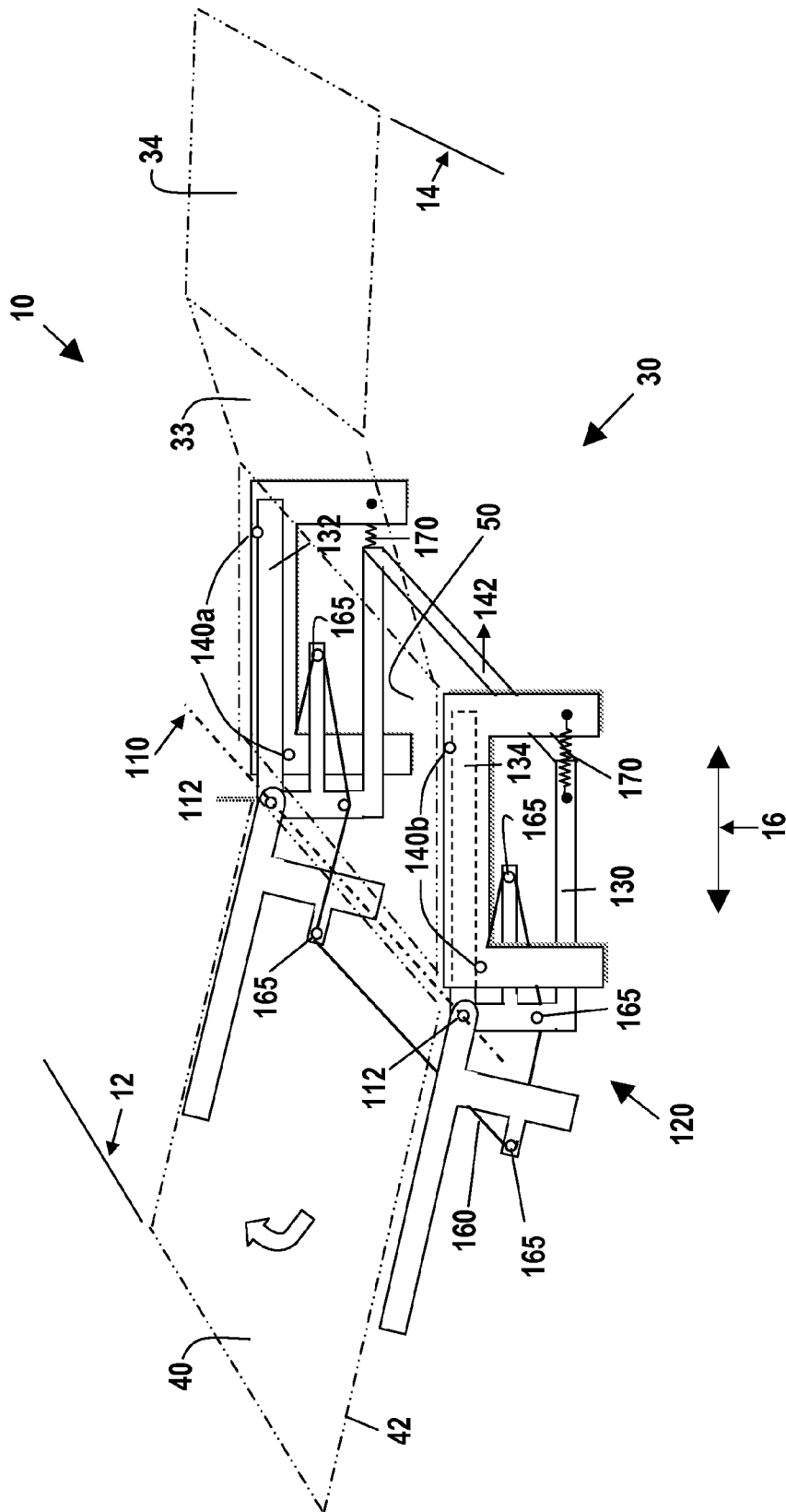

Fig. 1

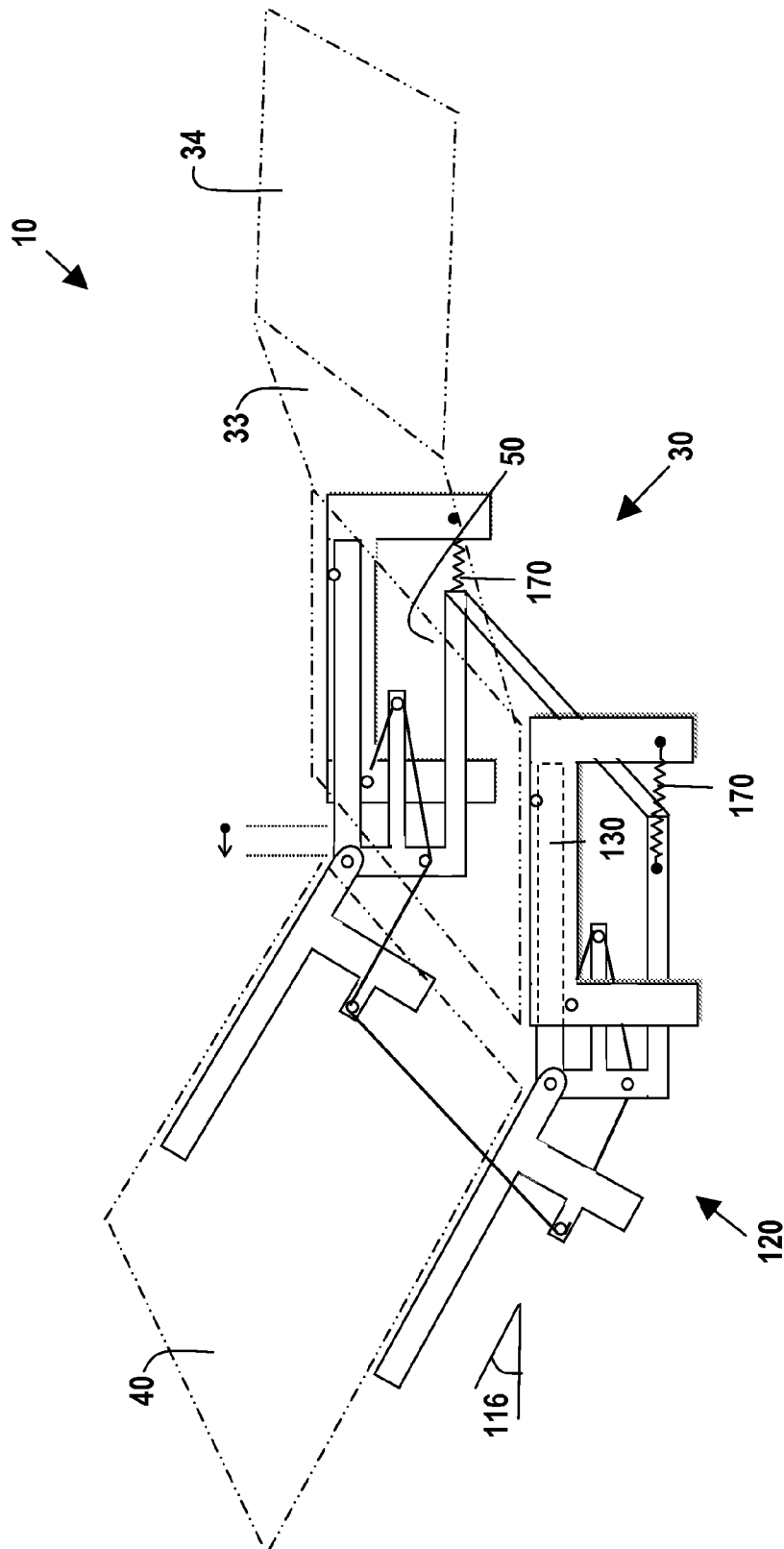

Fig. 2

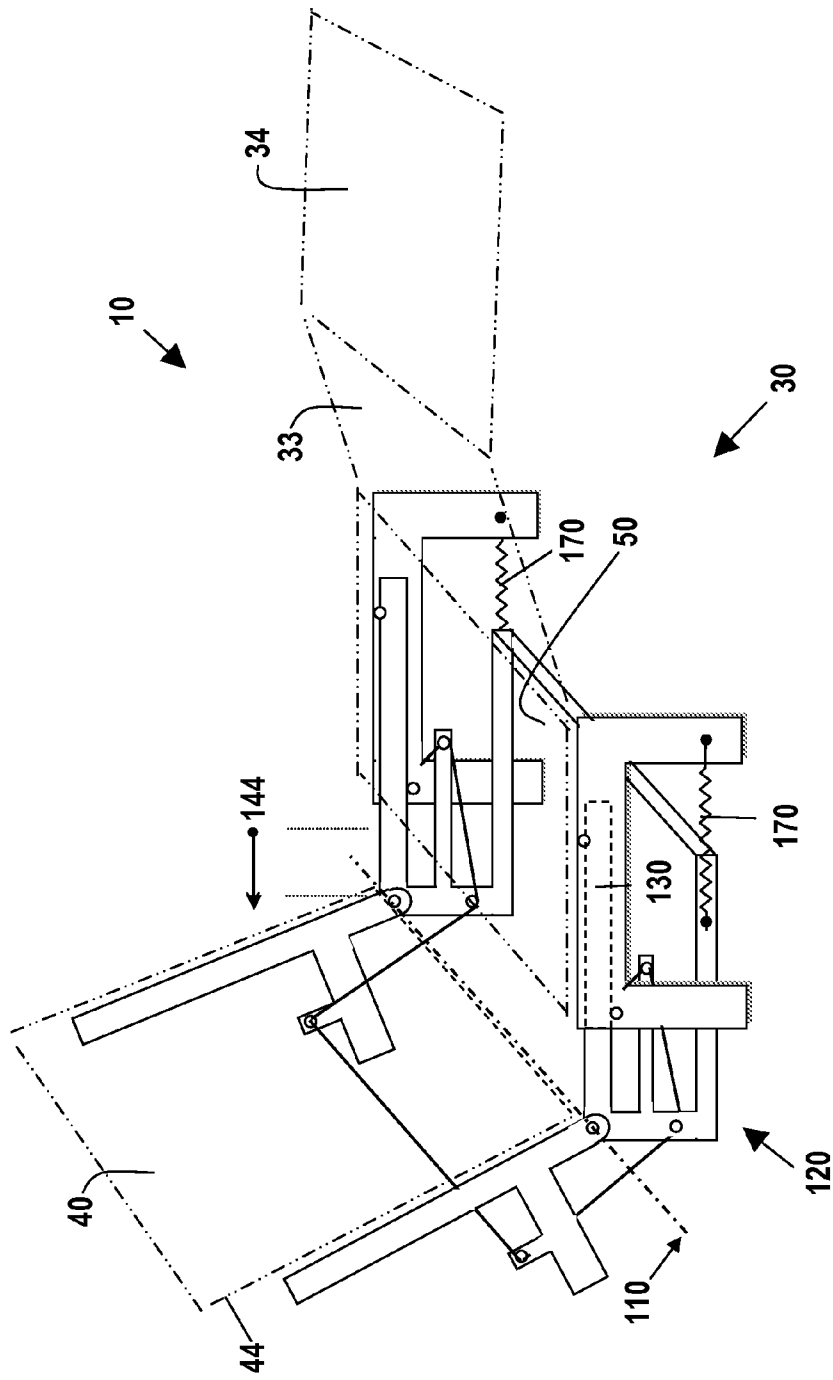

Fig. 3

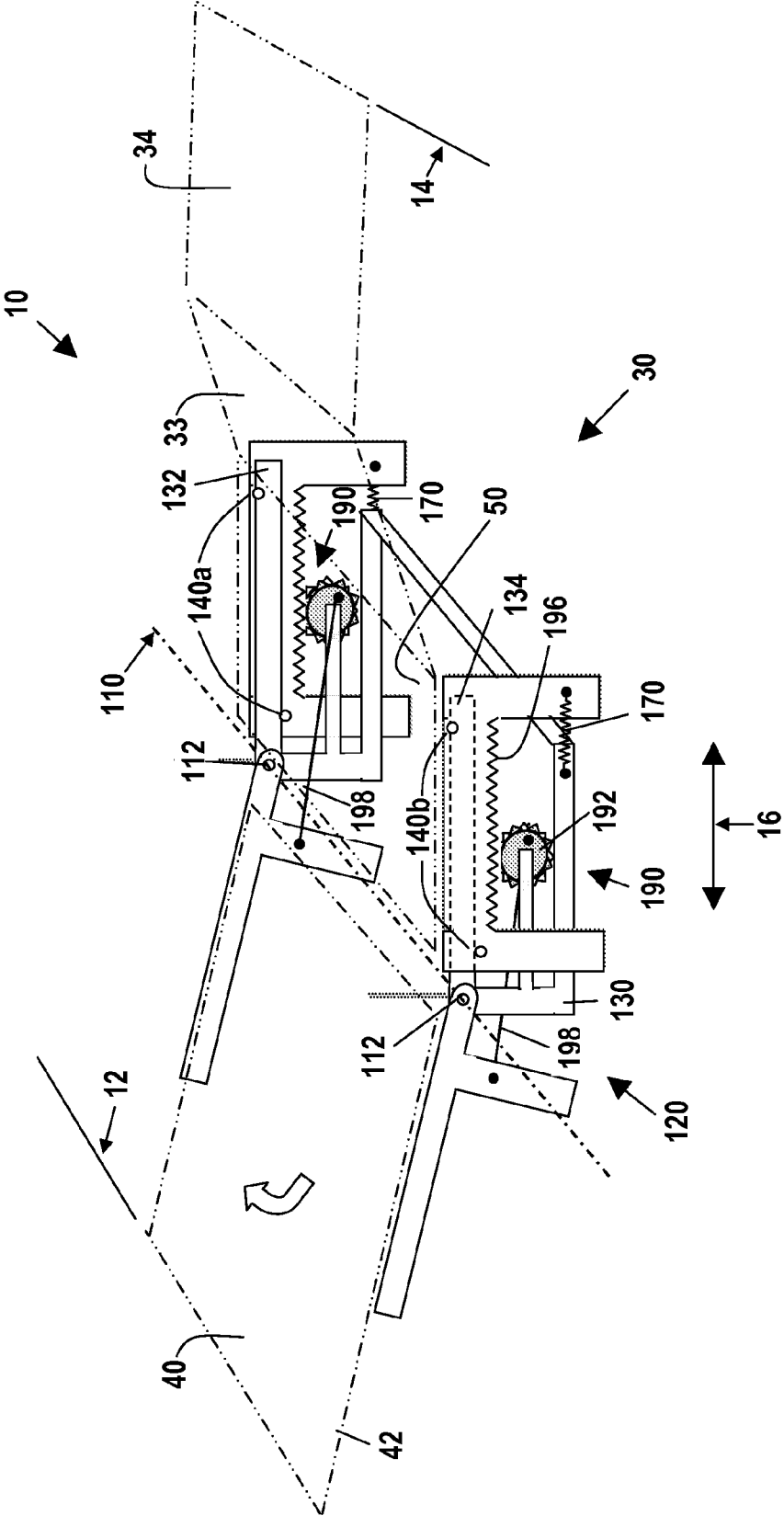

Fig. 4

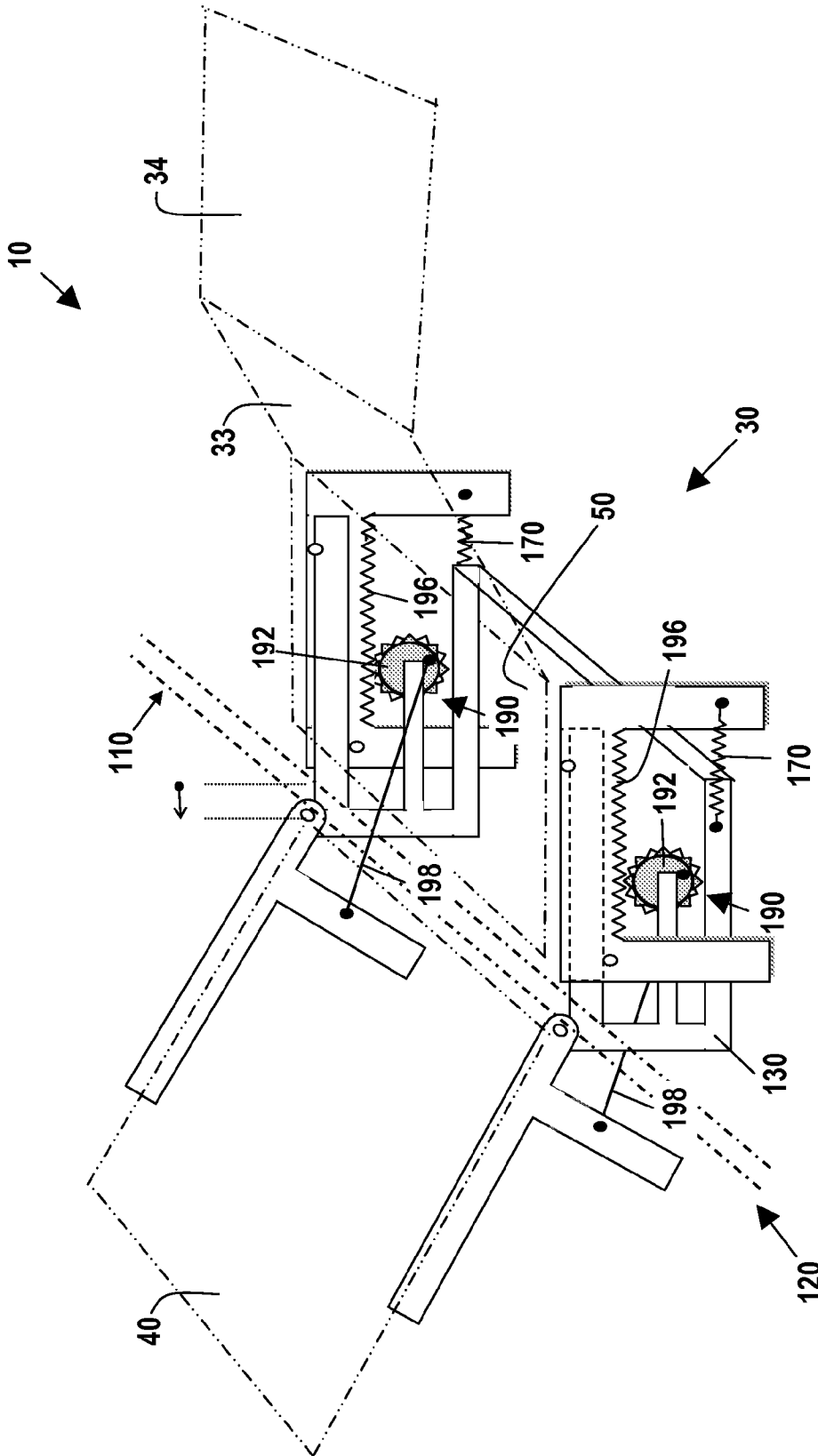

Fig. 5

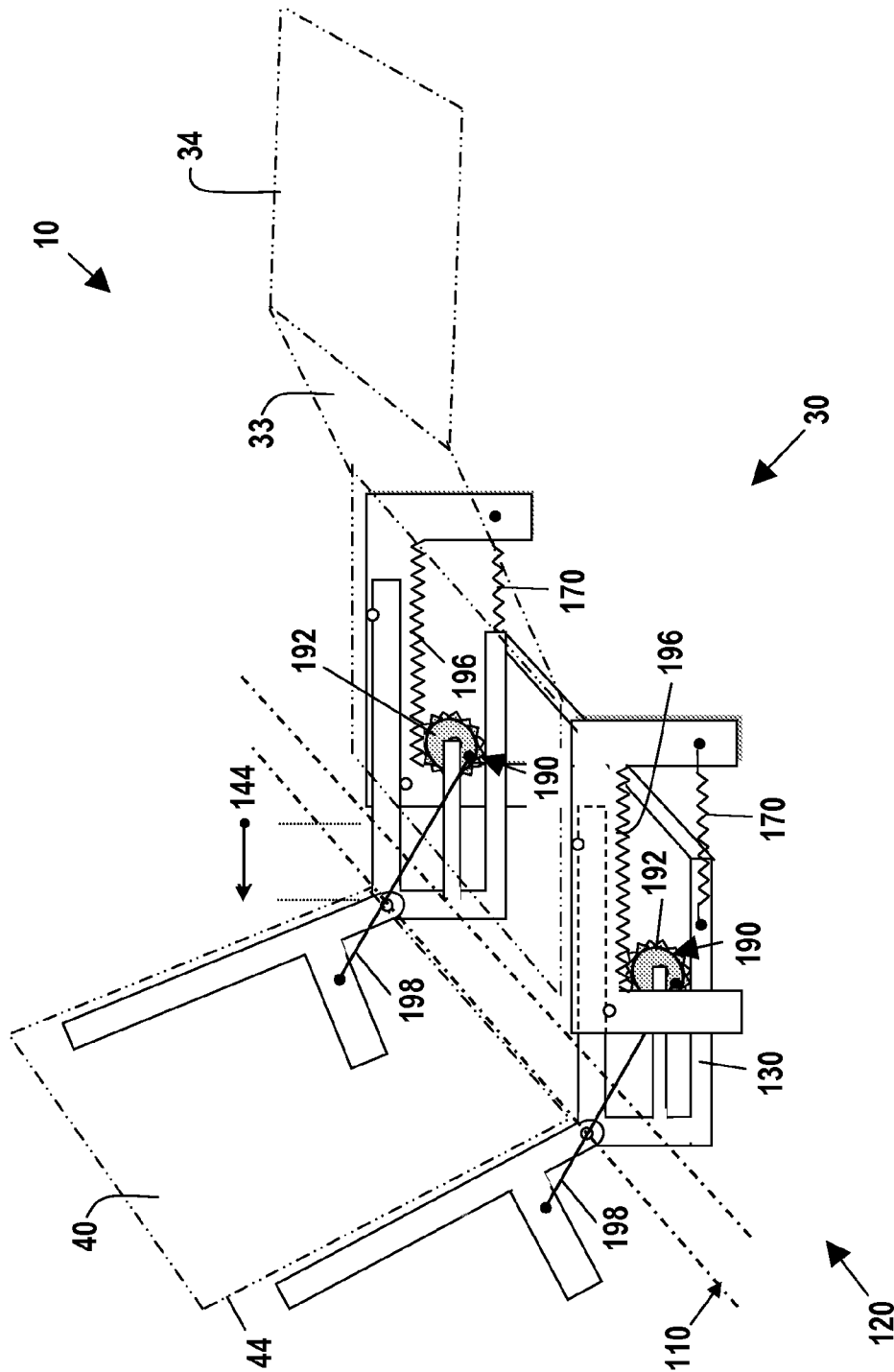

Fig. 6

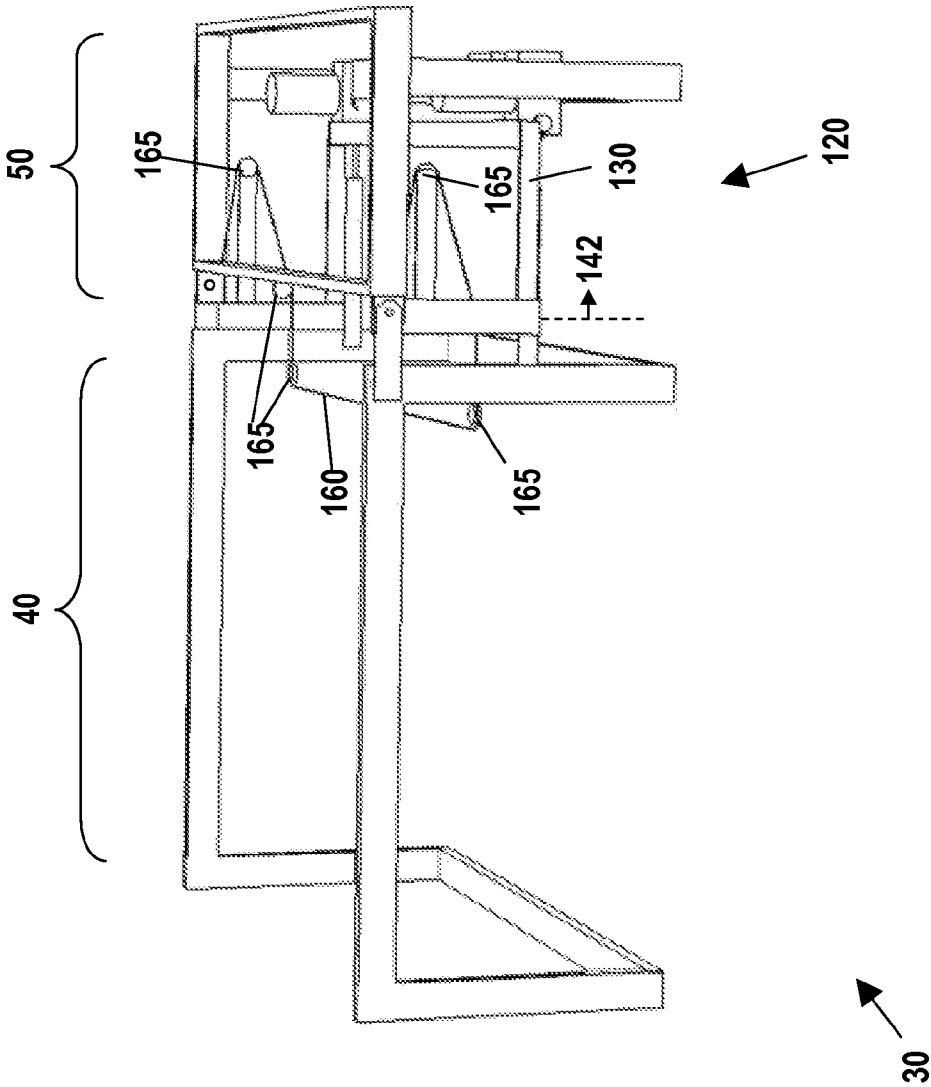

Fig. 7

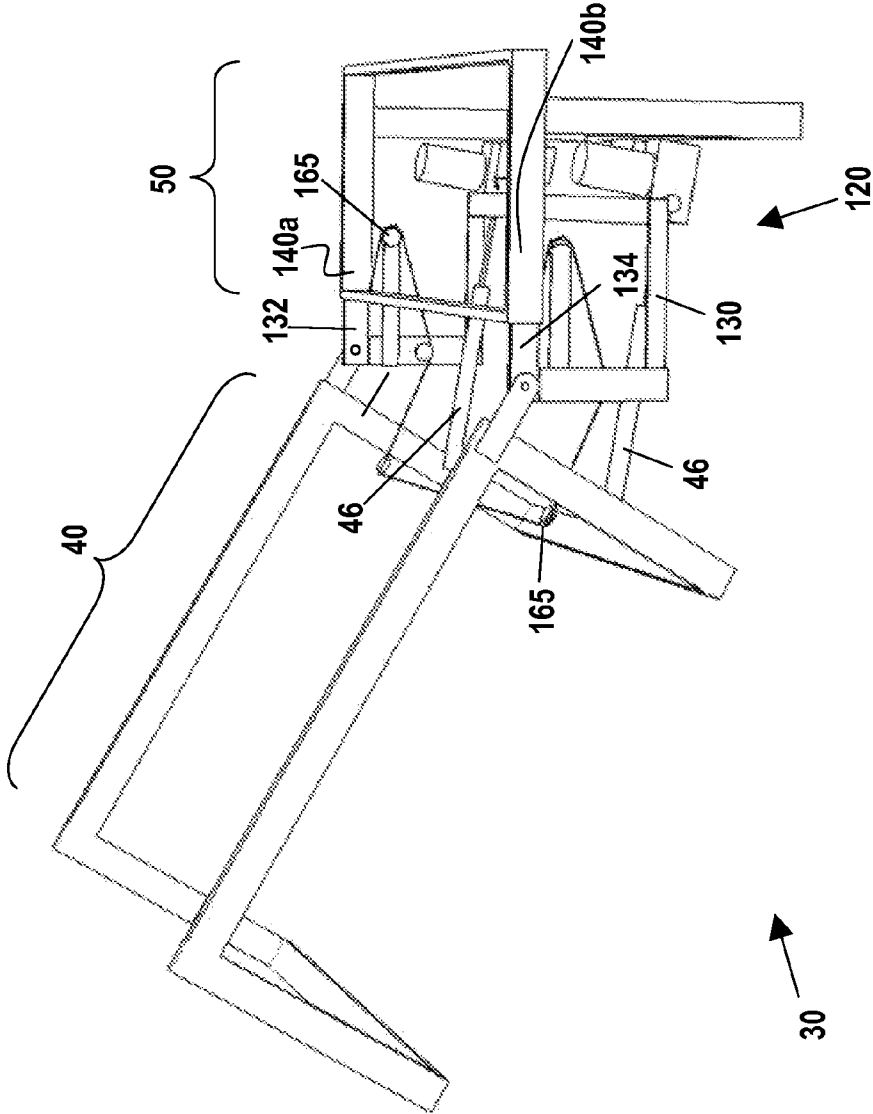

Fig. 8

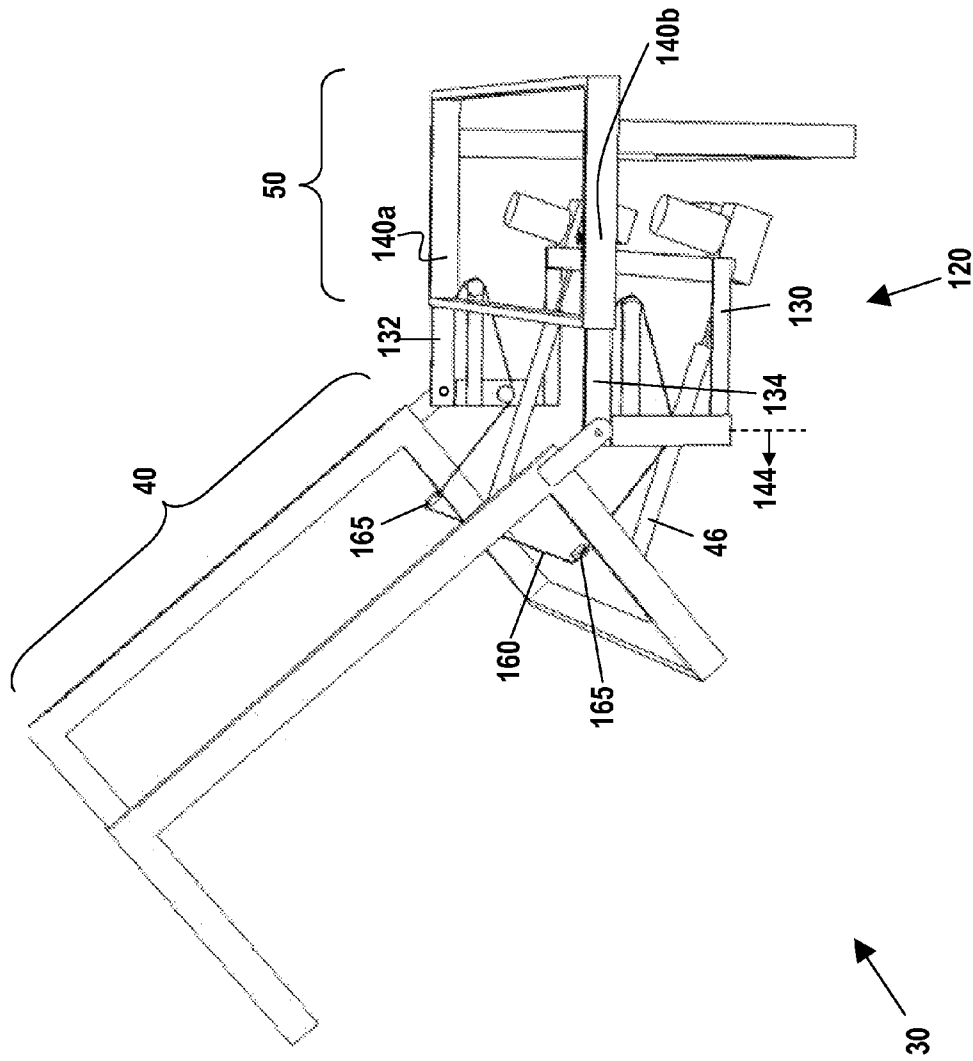

Fig. 9

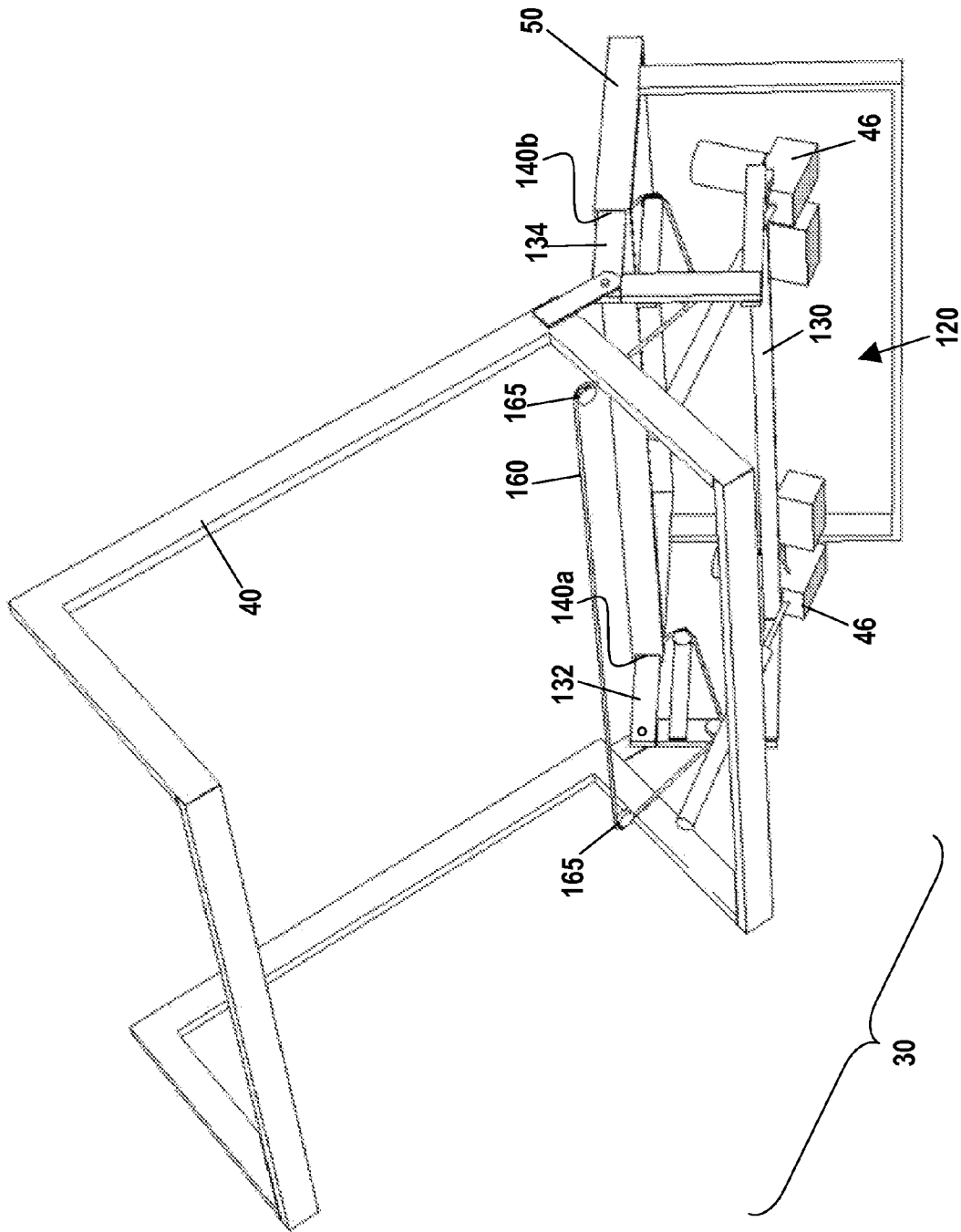

Fig. 10

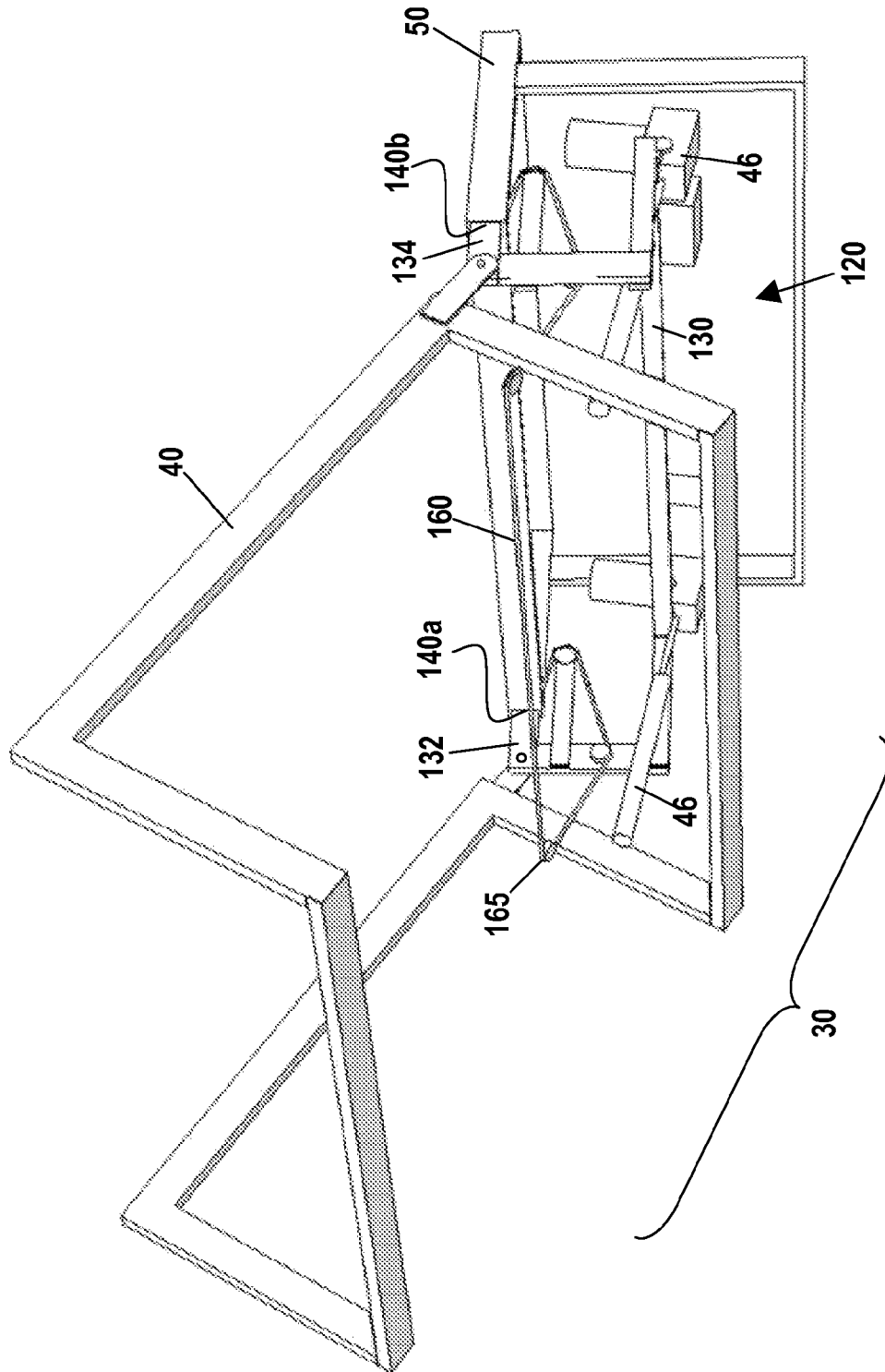

Fig. 11

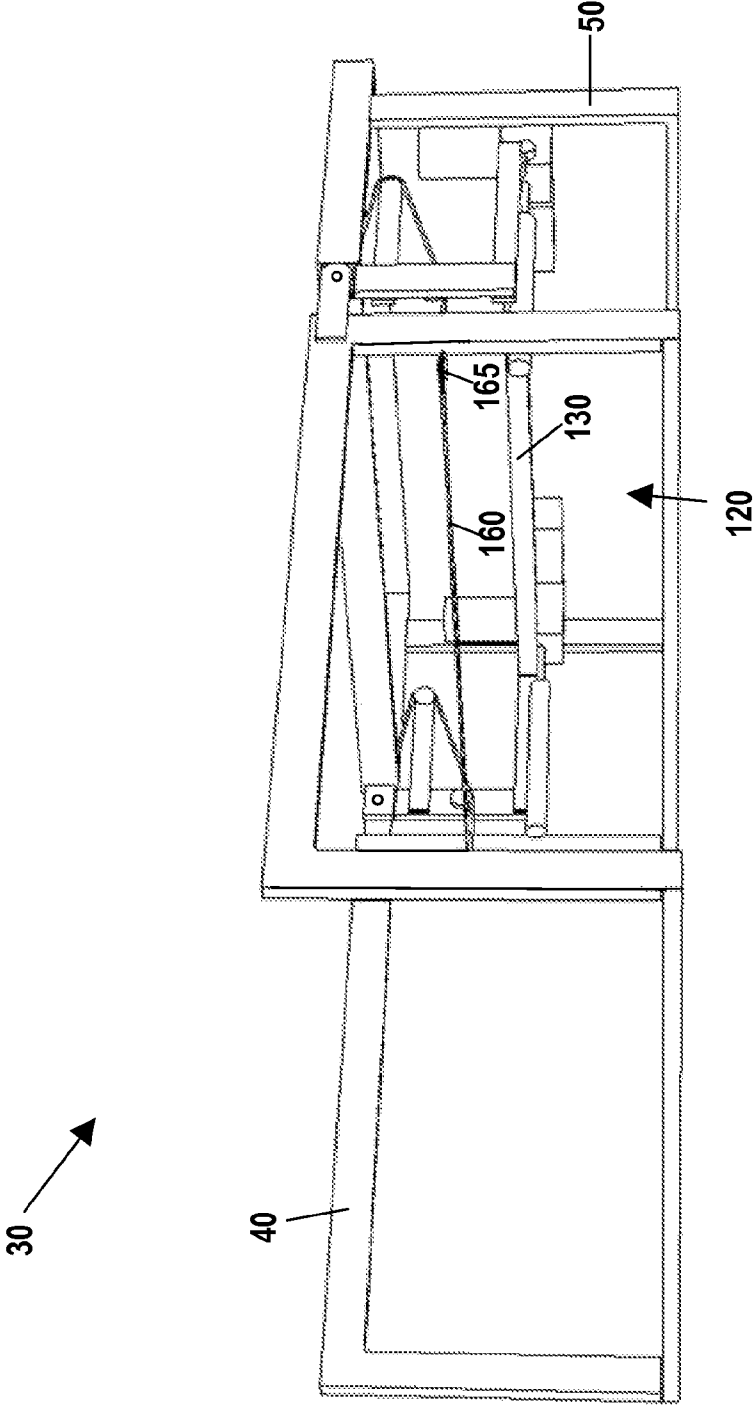

Fig. 12

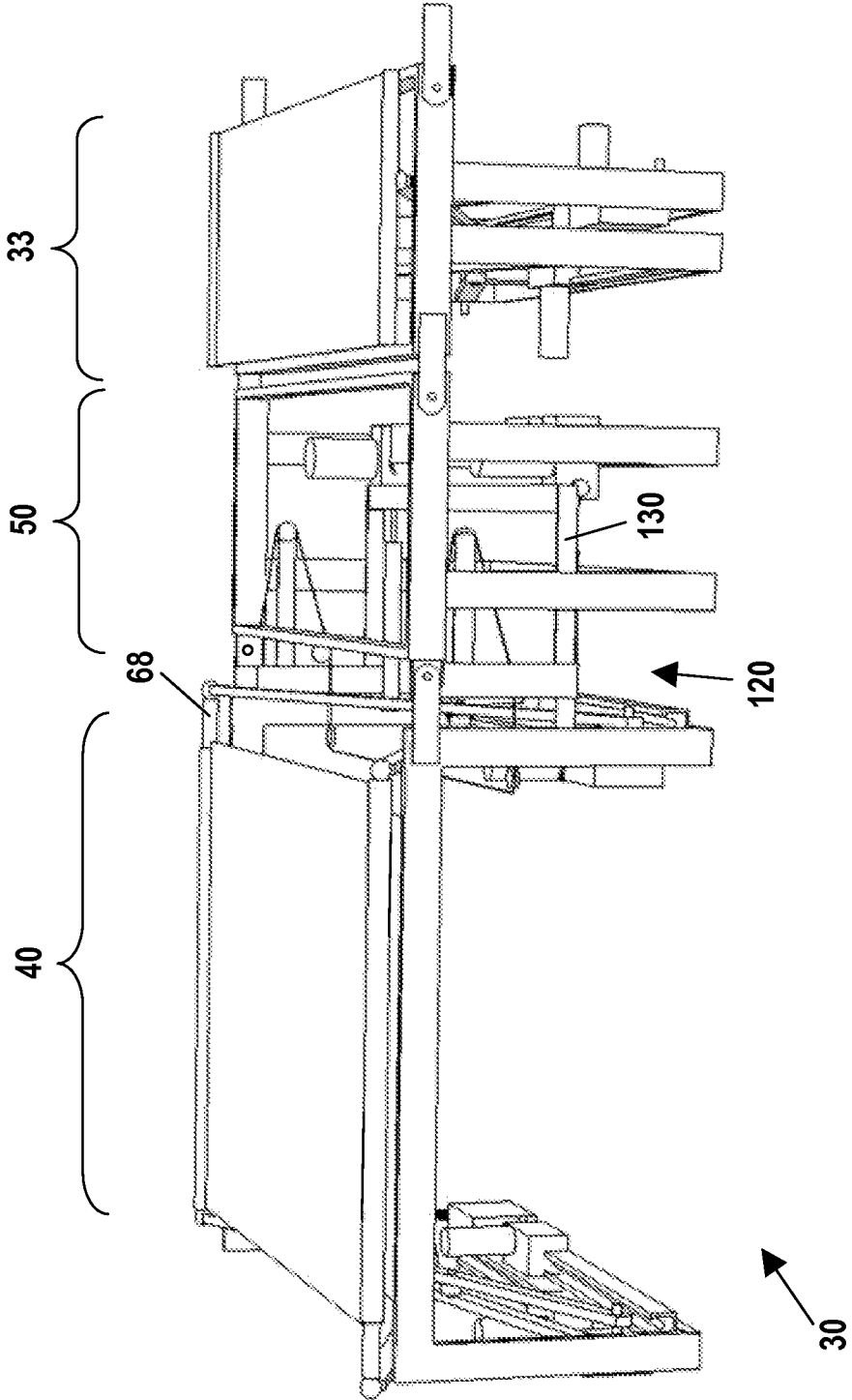

Fig. 13

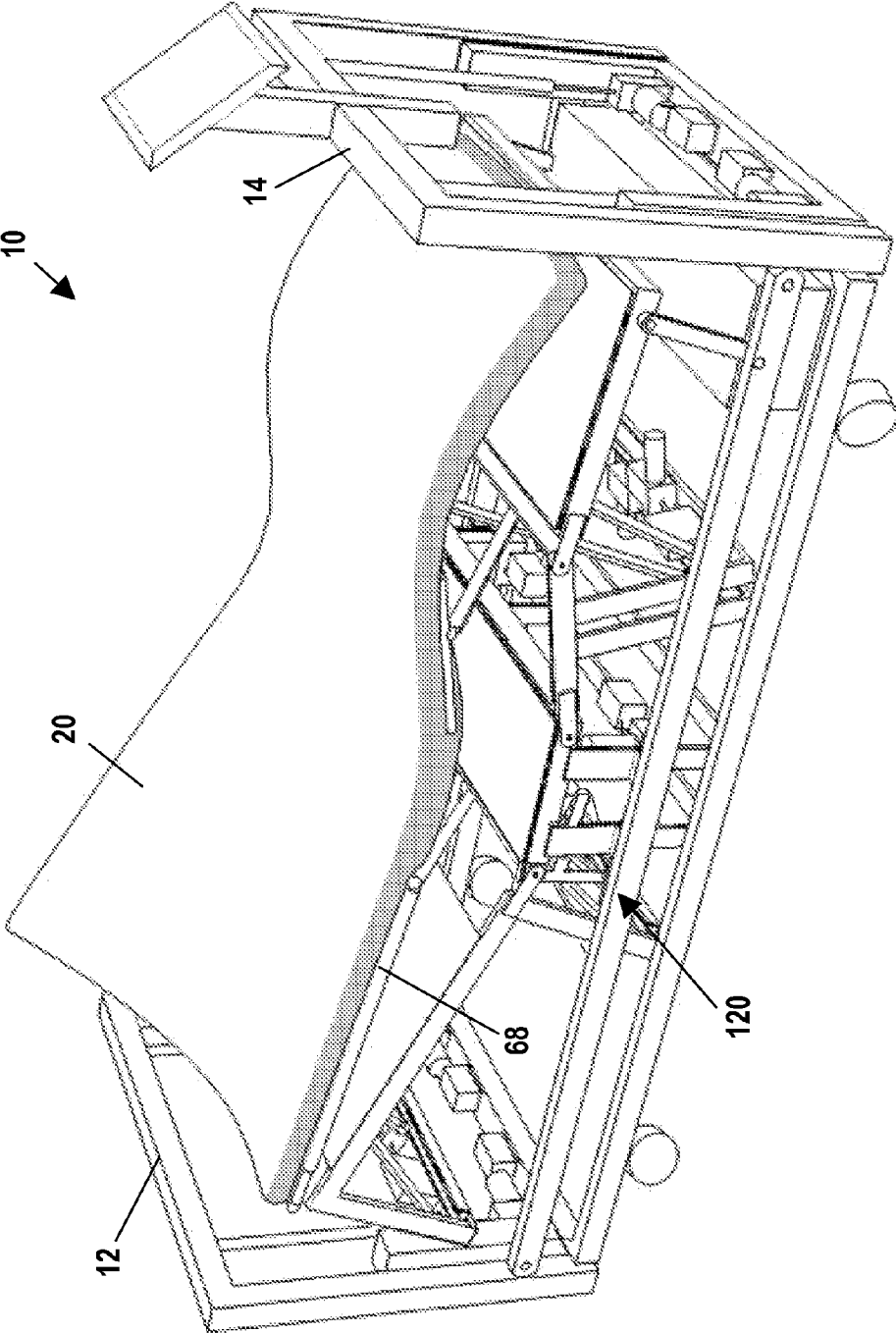

Fig. 14

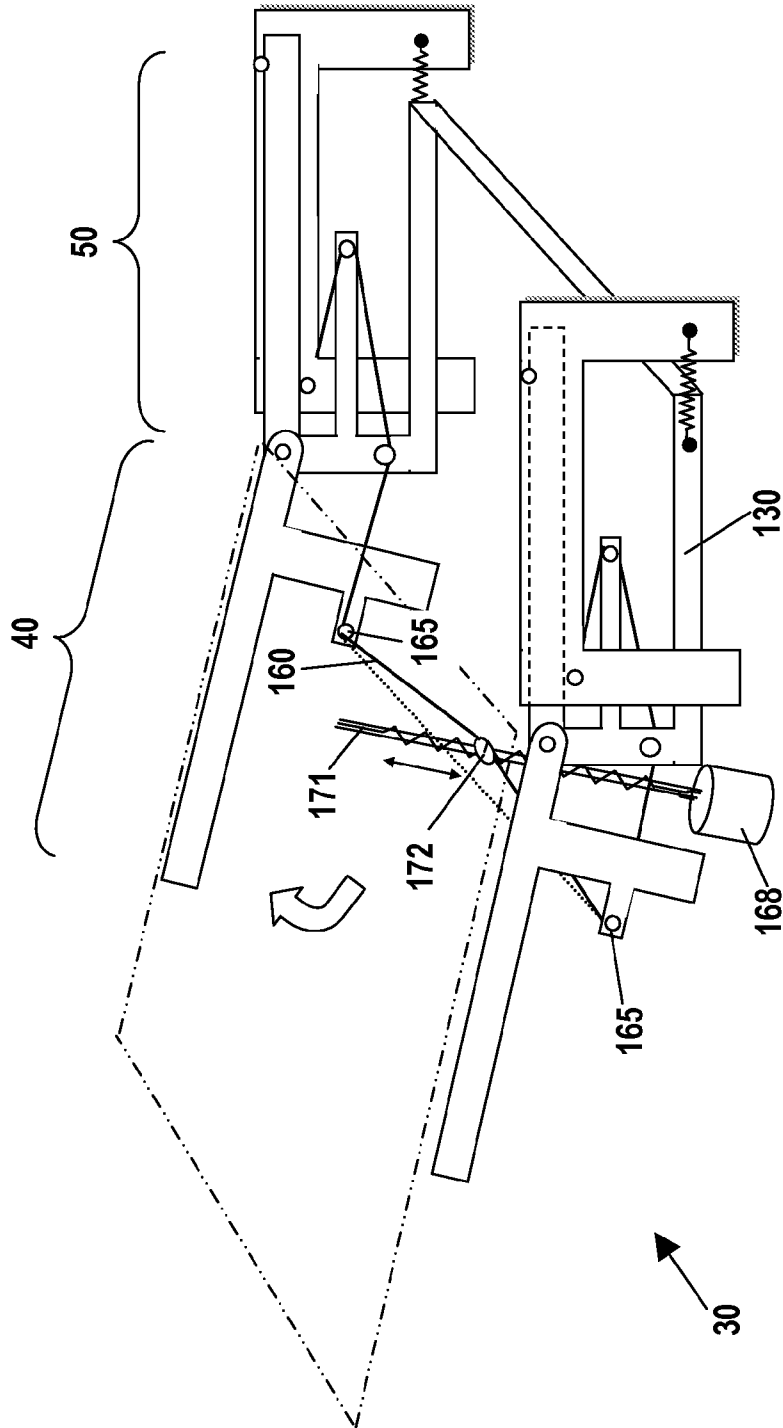

Fig. 15

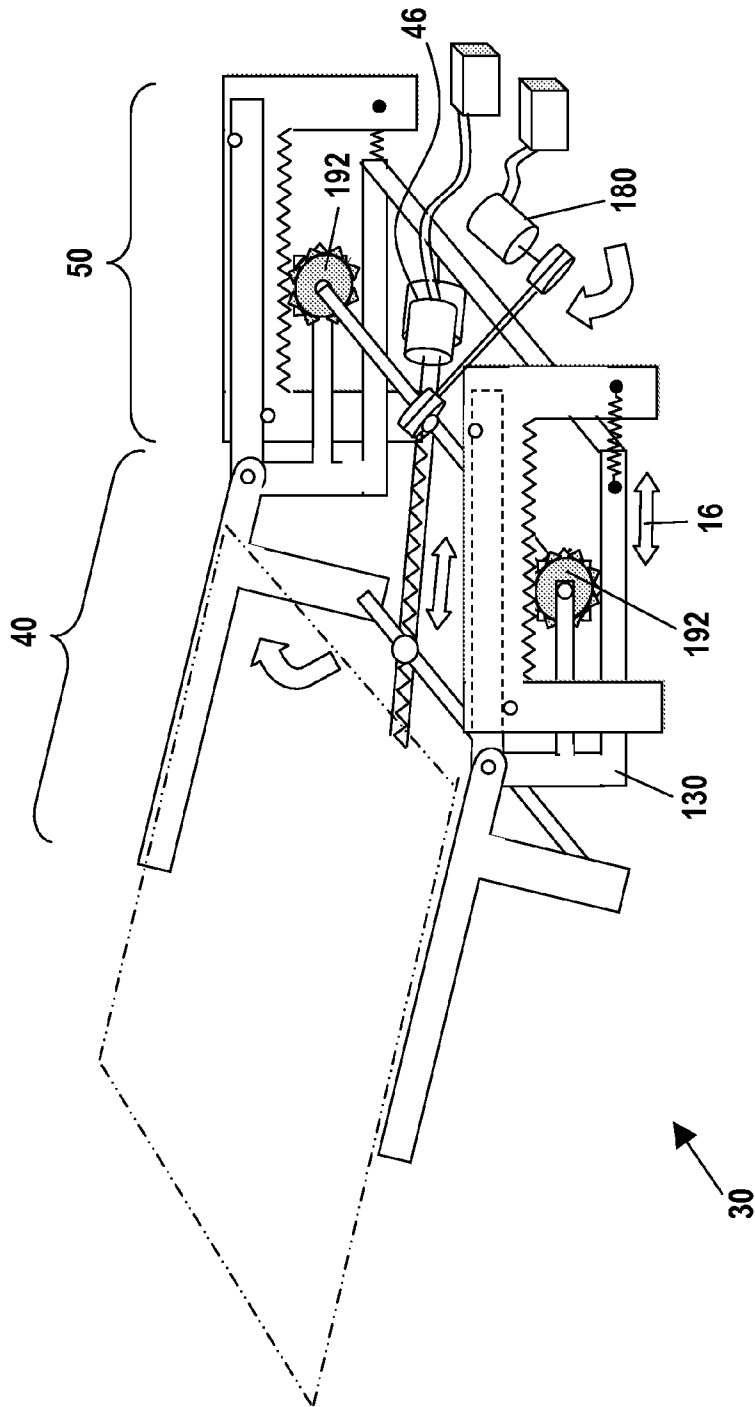

Fig. 16

**ADJUSTABLE BED WITH SLIDING  
SUBFRAME FOR TORSO SECTION**

## RELATED DISCLOSURES

This invention relates to, and this application incorporates herein by reference, the disclosure by Eduardo R. Benzo, Rodolfo W. Ferraresi, and Mario C. Eleonori entitled Device and Method for Release Lumbar Pressure in Adjustable Beds (Slideback) filed as part of the Patent and Trademark Office's Document Disclosure Program and given DDP number 610041.

## FIELD OF THE INVENTION

This invention relates generally to specialized beds and surfaces, and more particularly, to articulating hospital beds.

## BACKGROUND OF THE INVENTION

Normally in adjustable specialty beds, when the torso is elevated more than 30 degrees, the lower portion of the torso surface compresses the lumbo-sacral area and induces the patient to slide toward the footboard area of the bed. This not only causes discomfort, but also increases the risks of shear-lesion and pressure ulceration.

Accordingly, there is a need for a mechanism that minimizes compression of the lumbo-sacral area during articulation of the torso surface toward an inclined position.

## SUMMARY OF THE INVENTION

An axis displacement mechanism is provided that translates the rotational axis of the torso-supporting section of a multi-sectioned articulating specialty bed toward the headboard as the torso-supporting section is raised to an inclined position. This mechanism may be incorporated into a large variety of adjustable beds.

In the preferred form, the axis displacement mechanism comprises two sliding telescopic mechanisms on opposite lateral sides of the bed. The outer portions of the telescopic mechanism, which act as guides, are bound to the bed's chassis. The inner bars of the telescopic mechanism are rotatably connected to the torso-supporting section of the bed.

In one embodiment, the axis displacement mechanism is actuated by a traction cable system. A steel cable is affixed at its ends to the bed's chassis. The cable is mounted on pulleys placed on selected points of the axis displacement mechanism and on the structure of the torso-supporting section, defining a circuit. When the torso surface is elevated, it forces traction of the flexible steel cable, forcing the inner bars of the telescopic mechanisms into extension, which in turn translates the torso rotational axis in the headboard direction. One or more traction springs bias the axis displacement mechanism toward the retracted position, so that the torso rotational axis will translate back to its original position as the torso surface is lowered. By regulating the length and amount of slack in the cable, one can preset an initiation angle at which the torso rotational axis begins to be forced backed. In this embodiment, the relative position of the torso rotational axis is a function of the elevation angle of the torso surface.

In another embodiment, one or more electric or hydraulic actuators are provided to act on the sliding telescopic mechanisms. In such an embodiment, the actuator regulates the extension and retraction of the torso rotational axis independently of the elevation angle of the torso surface.

It is the inventors' intent that the scope of any of the claims be defined by the language of the claims, and not narrowed by reference to the preferred embodiments described in this summary or in the detailed description of the invention.

## BRIEF DESCRIPTION OF THE DRAWINGS

FIG. 1 illustrates one embodiment of a simple adjustable bed having a traction-wire-based sliding torso section subframe in a retracted position.

FIG. 2 illustrates the adjustable bed of FIG. 1 in a partially inclined position, with the bed's sliding torso section subframe in a partially extended position.

FIG. 3 illustrates the adjustable bed of FIG. 1 in a significantly inclined position.

FIG. 4 illustrates an alternative embodiment of an adjustable bed having a rack-and-pinion-based sliding torso section subframe in a retracted position.

FIG. 5 illustrates the adjustable bed of FIG. 4 in a partially inclined position, with the bed's sliding torso section subframe in a partially extended position.

FIG. 6 illustrates the adjustable bed of FIG. 4 in a significantly inclined position.

FIG. 7 illustrates a patient support structure with one embodiment of a traction-wire based sliding subframe.

FIG. 8 illustrates the patient support structure of FIG. 7 with the torso section in a partially inclined position.

FIG. 9 is a from-the-side perspective view of the patient support structure of FIG. 7 with the torso section in a significantly inclined position.

FIG. 10 illustrates the patient support structure of FIG. 9 from an oblique perspective.

FIG. 11 illustrates the patient support structure of FIG. 8 from an oblique perspective.

FIG. 12 illustrates the patient support structure of FIG. 7 from an oblique perspective.

FIG. 13 illustrates another, more sophisticated embodiment of a patient support structure with a sliding torso section subframe.

FIG. 14 illustrates an adjustable bed with a sliding torso section subframe.

FIG. 15 illustrates the patient support structure of FIG. 7 with a cable slack adjustment mechanism.

FIG. 16 illustrates a patient support structure having a rack-and-pinion-based sliding torso section subframe with a motorized actuator for driving the gearwheels.

## DETAILED DESCRIPTION

In describing preferred and alternate embodiments of the technology described herein, as illustrated in FIGS. 1-16, specific terminology is employed for the sake of clarity. The technology described herein, however, is not intended to be limited to the specific terminology so selected, and it is to be understood that each specific element includes all technical equivalents that operate in a similar manner to accomplish similar functions.

FIGS. 1-16 illustrate perspective views of different embodiments of an adjustable, articulatable bed 10 that extends along a longitudinal dimension 16 between a head end 12 and a foot end 14. To more fully illustrate the axis-displacement mechanism 120 of the bed 10, the patient support surface, head board, side board, and other aspects of the bed 10 are not shown in FIGS. 1-13.

The adjustable bed 10 comprises an articulatable, multi-sectioned patient support structure 30. The patient support structure 30 includes an articulating torso-supporting section

40, a derriere-supporting section 50, and preferably also an articulating upper-leg support structure 33 and an articulating lower-leg supporting structure 34. The derriere-supporting section 50 may also articulate, but for simplicity, FIGS. 1-16 depict embodiments with a derriere-supporting section 50 designed for rigid attachment to the main bed frame (not shown). Also for simplicity, FIGS. 7-12 and 15-16 depict only the torso and derriere-supporting sections 40 and 50 of the patient support structure 30.

To reduce compression of the lumbo-sacral area during articulation, the lower portion of the torso-supporting section 40 slides back as the torso-supporting section 40 is articulated toward an inclined position. The torso-supporting section 40 rotates about a transversal axis of rotation 110. As the torso-supporting section 40 rotates from a level (FIGS. 7, 13) or substantially level position 42 (e.g., FIG. 1) to an inclined position 44 (e.g., FIGS. 2, 3), an axis-displacement mechanism 120 causes the transversal axis of rotation 110 to slide back, along the bed's longitudinal dimension 16, toward the bed's head end 12. As the torso-supporting section 40 rotates from an inclined position 44 to a level position 42, the axis-displacement mechanism 120 causes the transversal axis of rotation 110 to slide forward, toward the bed's foot end 14.

The axis-displacement mechanism 120 comprises a sliding subframe 130 mounted on a guide mechanism 140a, 140b. The sliding subframe 130 comprises two parallel sliding arms or bars 132, 134 supporting and rotatably joined to the torso-supporting section 40 via hinges 112, which define the transversal axis of rotation 110. The guide mechanism, which is mounted on or adjacent to the derriere-supporting section 50, comprises two guides 140a, 140b positioned on opposite lateral sides of the derriere-supporting section 50. These guides 140a and 140b are adapted to guide the sliding arms or bars 132, 134 of the sliding subframe 130 between a retracted position 142 and an extended position 144 along the bed's longitudinal dimension 16, thereby translating the transversal axis of rotation 110 along the longitudinal dimension 16. The fully retracted and fully extended positions 142 and 144 of the sliding subframe 130 define opposite limits of translation of the transversal axis of rotation 110.

FIGS. 1-3 illustrate a traction-cable-based embodiment of the axis-displacement mechanism 120. Each end of a long traction cable 160 is fixedly attached to opposite sides of the bed 10 in the region of the derriere-supporting section 50. The traction cable 160 is mounted along intermediate points of its length on several pulleys 165 positioned on the sliding frame and the torso-supporting section 40. Articulation of the torso-supporting section 40 toward the inclined position 44 tensions the traction cable 160, which in turn pushes the sliding bars 132, 134 from their retracted positions 142 toward their extended positions 144. Although a single long traction cable 160 is preferred, two separate traction cables 160 can replace the single long traction cable 160 depicted in FIGS. 1-3. At least one, and preferably two traction springs 170 are provided to bias the sliding bars 132, 134 toward their retracted positions 142. In this manner, the bars 132, 134 return to their retracted positions 142 as the torso-supporting section 40 articulates from the inclined position 44 back toward the substantially level position 42.

In preferred embodiments, the axis-displacement mechanism 120 is adapted to initiate translation of the transversal axis of rotation 110 toward the head end 12 of the bed 10 when the torso-supporting section 40 reaches a preset initiation angle 116 (FIG. 2) of twenty-five degrees or more. For this purpose, a cable-slack adjustment mechanism 168 (FIG. 15) (such as a clamp or screw) is provided to regulate the length and amount of slack in the traction cable 160. More particu-

larly, FIG. 15 illustrates a leadscrew 171 that moves a lead-screw nut 172 along the screw axis. The leadscrew nut is connected to an eyehook (not shown) through which the cable 160 is threaded between two of the pulleys 165. Movement of the leadscrew 171 controls the amount of slack by drawing the cable 160 away from or toward the segment connecting the adjacent pulleys 165. The amount of slack in the cable 160 regulates the initiation angle 116 for initiating translation of the transversal axis of rotation 110.

FIGS. 4-6 illustrate a rack-and-pinion-based embodiment of the axis-displacement mechanism 120. In this embodiment, rack and pinion mechanisms 190 are positioned on opposite lateral sides of the derriere-supporting section 50. Each rack and pinion mechanism 190 comprises a gearwheel 192 mounted on the sliding subframe 130 that engages teeth 196 on the derriere-supporting section 50. Sliding arms 132 and 134 of the sliding subframe 130 are, as in FIGS. 1-3, adapted to move between retracted and extended positions within guides 140a, 140b mounted on the derriere-supporting section 50.

In a typical embodiment, one or more electrically-powered mechanical actuators 46 (FIGS. 8, 16) will articulate the torso-supporting section 40 between its the level and inclined positions 42 and 44. In FIGS. 1-3, this machine-powered articulation in turn causes translation of the sliding subframe 130 and displacement of the axis of rotation 110 without the use of any additional mechanical actuators. Likewise, in FIGS. 4-6, this machine-powered articulation causes the gearwheels 192, which are linked to the torso-supporting section 40 via linkages 198, to rotate, which in turn causes translation of the sliding subframe 130 and displacement of the axis of rotation 110 without the use of any additional mechanical actuators. FIG. 16 depicts an alternative embodiment. Here, the displacement of the axis of rotation 110 would be effected by one or more additional motorized actuators 180 (FIG. 16) mounted to the adjustable bed 10 to drive the gearwheels 192, which in turn drives the sliding frame 130 between its retracted and extended positions 142 and 144.

FIGS. 13 and 14 illustrate an embodiment of the sliding subframe mechanism incorporated into a mechanical bed of the type described and depicted in application Ser. No. 11/869,696 entitled "Bed with Adjustable Patient Support Framework" filed on Oct. 9, 2007, which application is herein incorporated by reference. In particular, an adjustable bed 10 is depicted having a patient support surface 20, a torso-supporting section 40 with a torso support litter 68 and an axis-displacement mechanism 120 for the torso-supporting section 40. But it should be understood that the invention is not so limited, unless explicitly so limited by the claims, and can be incorporated in a large variety of hospital and non-hospital beds.

This specification also incorporates by reference the following disclosures filed as part of the Patent and Trademark Office's Document Disclosure Program: the disclosure by Eduardo R. Benzo and Rodolfo W. Ferraresi entitled Levita-Bed System, filed on Dec. 12, 2005, and assigned document number 592241; the disclosure by Eduardo R. Benzo, Rodolfo W. Ferraresi, and Mario C. Eleonori entitled Dynamic Multipositional Hospital Bed, filed on Feb. 15, 2006, and assigned document number 596795; the disclosure by Eduardo R. Benzo, Rodolfo W. Ferraresi, and Mario C. Eleonori entitled Dynamic Multipositional Hospital Bed, filed on Jul. 6, 2006, and assigned document number 603707; the disclosure by Eduardo R. Benzo, Rodolfo W. Ferraresi, and Mario C. Eleonori entitled Use and Control Methods for Multipositional Beds, filed on May 12, 2006, and assigned document number 610034; and the disclosure by Eduardo R. Benzo,

5

Rodolfo W. Ferraresi, and Mario C. Eleonori entitled System for Virtual Communication between Patient and the Rest, filed on Dec. 5, 2006, and assigned document number 610042.

This invention also incorporates herein by reference, the following patent applications: App. No. 60/979,836 entitled "Patient Support Surface with Modulating Hip-Cradling Perimeter" filed on Oct. 14, 2007; App. No. 60/979,837 entitled "Adjustable Bed with Sacral Pressure Relieve Function" filed on Oct. 14, 2007; and App. No. 60/979,838 entitled "Modulating Support Surface to Aid Patient Entry and Exit" filed on Oct. 14, 2007.

Having thus described exemplary embodiments of the present invention, it should be noted that the disclosures contained in FIGS. 1-16 are exemplary only, and that various other alternatives, adaptations, and modifications may be made within the scope of the present invention. Accordingly, the present invention is not limited to the specific embodiments illustrated herein, but is limited only by the following claims.

We claim:

1. An adjustable bed comprising:

a head end and a foot end;

a patient support surface;

a patient support structure for supporting the patient support surface;

the patient support structure comprising a plurality of adjacent lateral patient support sections, including a first support section adjacent to second support section;

the first support section being adapted to support the torso of a patient lying on the patient support surface;

the first support section being adapted to articulate about a transversal axis of rotation between a substantially level position and an inclined position; and

an axis-displacement mechanism mounted on the second support section, the axis-displacement mechanism being adapted to linearly and horizontally translate the transversal axis of rotation away from the second support section and toward the head end of the bed as the first support section articulates from the substantially level position toward the inclined position and to linearly and horizontally translate the transversal axis of rotation toward the second support section and toward the foot end of the bed as the first support section articulates from the inclined position toward the substantially level position.

2. The adjustable bed of claim 1, further comprising a mechanical actuator adapted to articulate the first support section between its substantially level and inclined positions.

3. The adjustable bed of claim 2, wherein movement of the axis-displacement mechanism is effected by articulation of first support section without the use of any additional mechanical actuators.

4. The adjustable bed of claim 2, wherein the axis-displacement mechanism comprises one or more additional motorized actuators mounted to the adjustable bed and adapted to translate the transversal axis of rotation between first and second limits of translation.

5. The adjustable bed of claim 4, wherein the axis-displacement mechanism further comprises a sliding subframe and one or more rack and pinion mechanisms, each comprising a gearwheel mounted on the sliding subframe, the gearwheel engaging teeth on the second support section in a manner adapted to move the subframe between retracted and extended positions within a guide mounted on the second support section;

6

wherein the one or more motorized actuators are adapted to drive the one or more gearwheels; and wherein translation of the transversal axis of rotation is effected by movements of the subframe.

6. The adjustable bed of claim 1, wherein the axis-displacement mechanism is adapted to initiate translation of the transversal axis of rotation toward the head end of the bed when the first support section reaches a preset initiation angle.

7. The adjustable bed of claim 6, wherein the preset initiation angle is at least 25 degrees.

8. The adjustable bed of claim 1, wherein the axis-displacement mechanism comprises one or more bars adapted to move between retracted and extended positions within a guide mounted on the second support section.

9. The adjustable bed of claim 8, wherein the axis-displacement mechanism further comprises one or more traction cables operable to cause the one or more bars to move from their retracted positions into their extended positions as the first support section articulates from the substantially level position toward the inclined position.

10. The adjustable bed of claim 9, wherein the traction cables are each mounted on the first and second support sections and on one or more pulleys, such that articulation of the first support section beyond an initiation angle tensions the traction cables, pushing the one or more bars into their extended positions.

11. The adjustable bed of claim 10, further comprising a cable slack adjustment mechanism operable to regulate the amount of slack in the traction cables when the first support section is in its substantially level position, the amount of slack defining an initiation angle for initiating translation of the transversal axis of rotation.

12. The adjustable bed of claim 9, wherein the axis-displacement mechanism further comprises a traction spring operable to cause the one or more bars to return from their extended positions to their retracted positions as the first support section articulates from the inclined position toward the substantially level position.

13. An articulatable bed with longitudinal and lateral dimensions extending between head and foot ends of the bed, the bed comprising:

a derriere-supporting section for supporting the derriere of a patient;

an articulating torso-supporting section adjacent the derriere-supporting section;

a transversal axis of rotation about which the articulating torso-supporting section rotates;

two sliding bars rotatably joined to articulating torso-support section at the transversal axis of rotation;

two guide mechanisms positioned on opposite lateral sides of the derriere-supporting section that are adapted to guide the two sliding bars between retracted and extended positions along the longitudinal dimension of the bed, thereby translating the transversal axis of rotation of the articulating torso-supporting section along the longitudinal dimension;

wherein articulation of the torso-supporting section from a substantially level position toward a significantly inclined position causes the transversal axis of rotation to slide back, along the longitudinal dimension, away from the derriere-supporting section; and articulation of the torso-supporting section from a significantly inclined position to a substantially level position causes the transversal axis of rotation to slide forward, along the longitudinal dimension, toward the derriere-supporting section.

**14.** The articulatable bed of claim **13**, further comprising one or more traction cables operable to cause the one or more bars to move from their retracted positions into their extended positions as the torso-supporting section articulates from the substantially level position toward the inclined position.

**15.** The articulatable bed of claim **14**, wherein the traction cables are each mounted on the first and second support sections and on one or more pulleys, such that articulation of the first support section beyond an initiation angle tensions the traction cables, pushing the one or more sliding bars into their extended positions.

**16.** The articulatable bed of claim **15**, wherein the axis-displacement mechanism further comprises a traction spring operable to cause the one or more sliding bars to return from their extended positions to their retracted positions as the torso-supporting section articulates from the inclined position toward the substantially level position.

**17.** An articulatable bed with longitudinal and lateral dimensions extending between head and foot ends of the bed, the bed comprising:

- a derriere-supporting section for supporting the derriere of a patient;
- an articulating torso-supporting section adjacent the derriere-supporting section;
- a transversal axis of rotation about which the articulating torso-supporting section rotates;
- a sliding subframe rotatably joined to the articulating torso-support section at the transversal axis of rotation;
- a guide mechanism mounted adjacent the derriere-supporting section that is adapted to guide the sliding subframe

between retracted and extended positions along the longitudinal dimension of the bed, thereby translating the transversal axis of rotation of the articulating torso-supporting section along the longitudinal dimension;

wherein articulation of the torso-supporting section from a substantially level position toward a significantly inclined position causes the transversal axis of rotation to slide back, along the longitudinal dimension, away from the derriere-supporting section; and articulation of the torso-supporting section from a significantly inclined position to a substantially level position causes the transversal axis of rotation to slide forward, along the longitudinal dimension, toward the derriere-supporting section.

**18.** The articulatable bed of claim **17**, further comprising a mechanical actuator adapted to articulate the torso-supporting section between its substantially level and inclined positions.

**19.** The articulatable bed of claim **18**, wherein translation of the sliding subframe between retracted and extended positions is effected by articulation of torso-supporting section without the use of any additional mechanical actuators.

**20.** The articulatable bed of claim **18**, wherein translation of the sliding subframe between retracted and extended positions is effected by one or more additional motorized actuators mounted to the adjustable bed and adapted to translate the sliding subframe between first and second limits of translation.

\* \* \* \* \*